

Slimline

Spec Sheet No. SL-10

Job Name _____

Item No. _____

Ice Bin / Cocktail Unit with cold plate

- SLJ-24-7
- SLJ-36-7

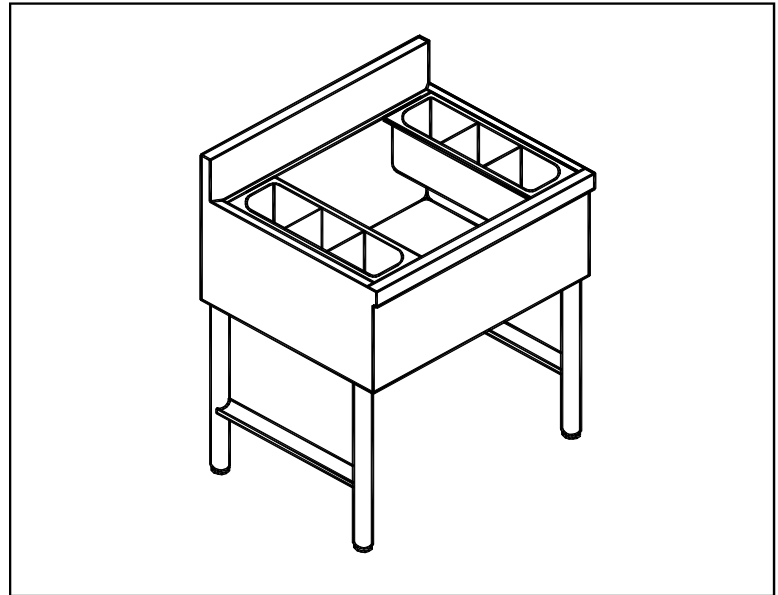

Specifications

•**Ice Bin:** 22 gauge 300 series stainless steel.

•**Front Apron:** 22 gauge 300 series stainless steel.

•**Sides:** 20 gauge 430 series stainless steel.

•**Backsplash:** 22 gauge 300 series stainless steel.

•**Insulation:** 2 lb. density styrofoam.

•**Bottle Rack:** (2) Injection molded plastic.

•**Under Structure:** 22 gauge galvaneal fronts and backs, 11 gauge electrogalvaneal leg channel.

•**Legs:** 1-5/8" O.D. 18 gauge galvanized with electro static black powder coat and black plastic adjustable bullet feet. To include stainless steel legs add the suffix -SS.(Optional)

•**Plumbing:** 1/2" I.P.S. drain.

•**Cold Plate:** Cast aluminum with 7 circuits sealed into the bottom. Tubing to have 5 syrup and 2 water lines with 5/16" diameter stainless steel bump and swedge ends.



Slimline

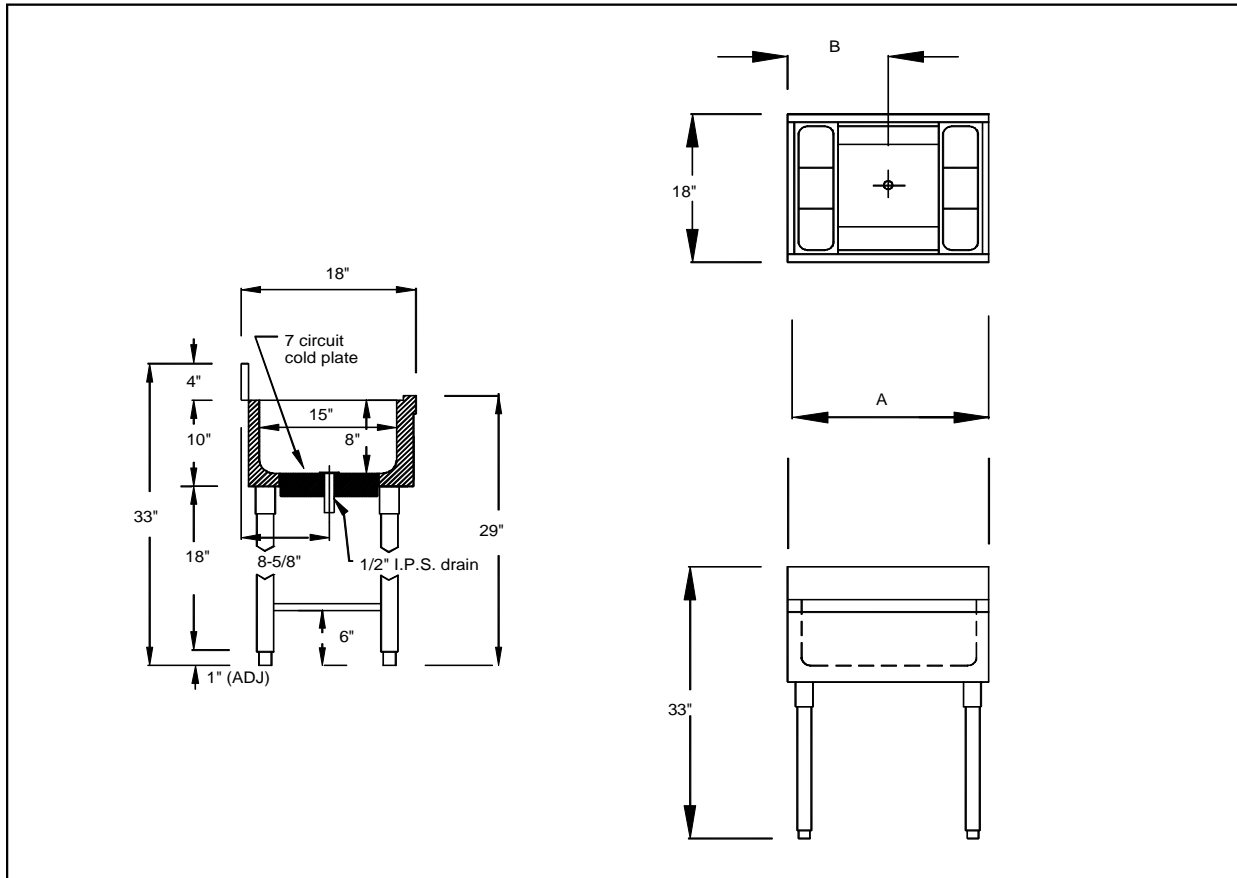

Model Number	Dimension A	Dimension B	Ice Capacity	Packaged Weight	Packaged Cubic Feet
SLJ-24-7	23"	11.5"	74 lbs.	82 lbs.	6
SLJ-36-7	35"	17.5"	110 lbs.	94 lbs.	9.3

SupremeMetal is constantly engaged in a program of improving their products. We reserve the right to change our specifications without prior notice.